

# Tutorial – Building circuits

## The solderless breadboard

You will be using a breadboard to prepare your electrical circuits. The breadboard is a solderless board that allows you to quickly prepare and test simple electronic circuits. [Figure 1a](#) below presents an example of a breadboard while [Figure 1b](#) shows the internal connection pattern (the interconnected breadboard holes are indicated by the solid lines).

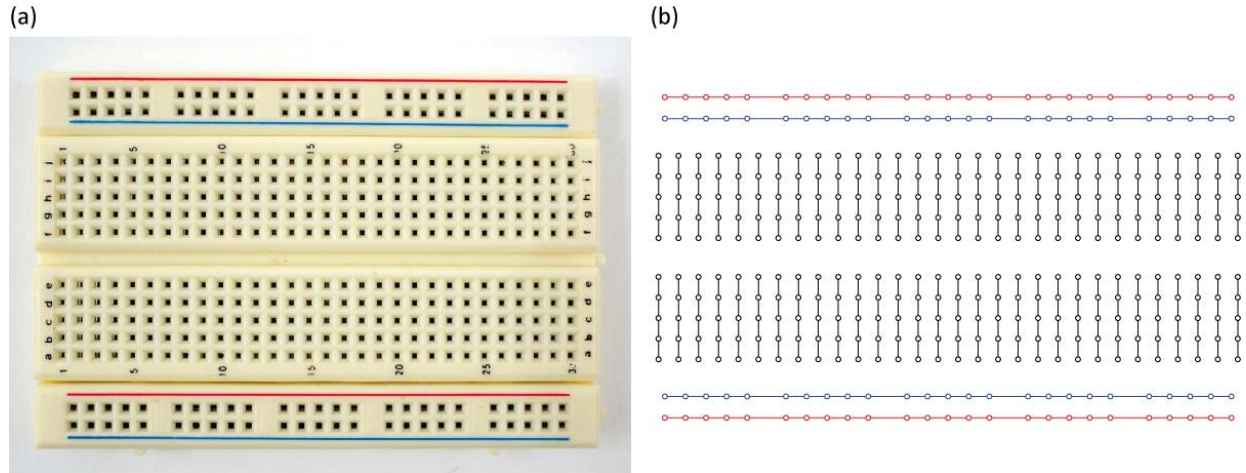

Figure 1 - (a) A solderless breadboard as the one you will use in the physics laboratory. (b) The hidden connection pattern.

Circuits are built on a breadboard simply by inserting wires and components such as resistors or capacitors in the holes of the board. [Figure 2](#) presents an example of a simple circuit and the way it can be reproduced using a breadboard. The red and blue horizontal lines are called bus strips are typically used to connect to the power supply (red is positive and blue is negative or grounded). This way, power can be brought to any part of the breadboard using sort wires to connect the bus lines to the terminal strips (black lines).

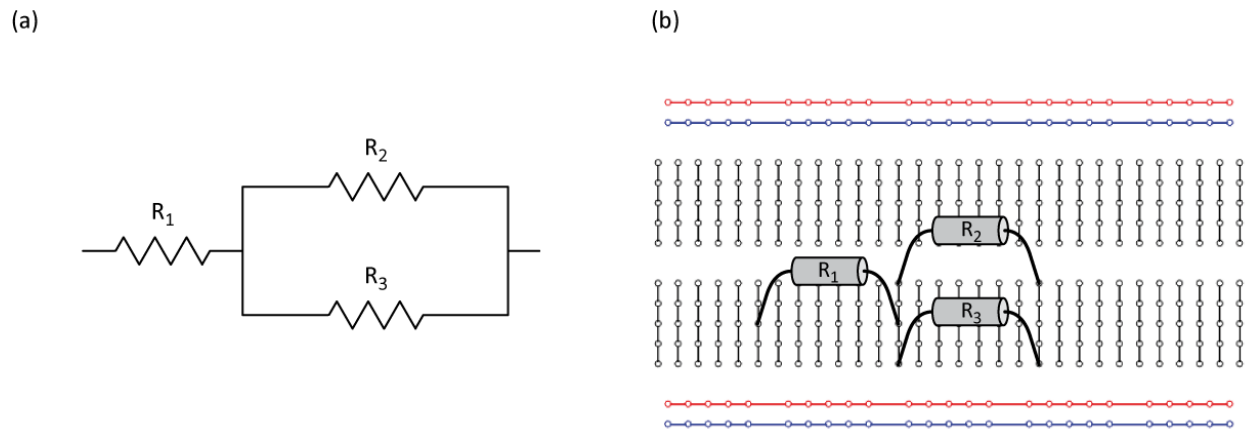
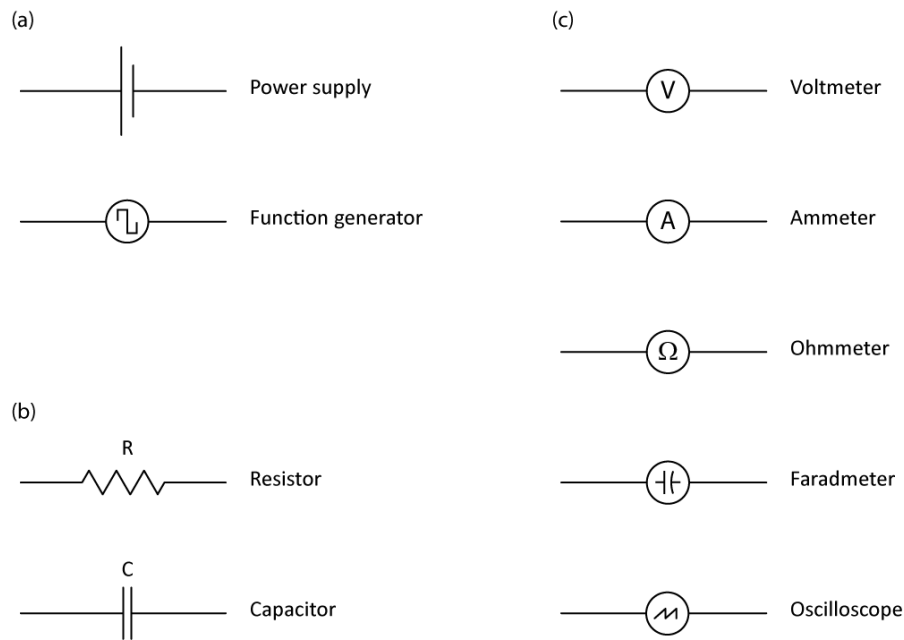

Figure 2 - (a) Circuit diagram of a resistor connected in series with a pair of resistors connected in parallel. (b) How to prepare the circuit presented in (a) using the hidden connections of a breadboard.

## Circuit diagrams

In [Figure 2a](#), we presented the circuit diagram of a resistor connected in series with two other connected in parallel. During your physics labs, you will have to read such circuit diagrams and assemble the corresponding circuits. [Figure 3](#) presents symbols we will use to represent the components (power supply, capacitor and resistor) and the measuring instruments (voltmeter, ammeter and ohmmeter) you will be working with during your physics labs.



**Figure 3 - Circuit diagram symbols for the physics labs. (a) Power sources. (b) Components. (c) Meters.**

As we mentioned above, the convention when using a power supply is to use the red and blue bus strips. Thus, a simple circuit with the same three resistors and one power supply would look like this:

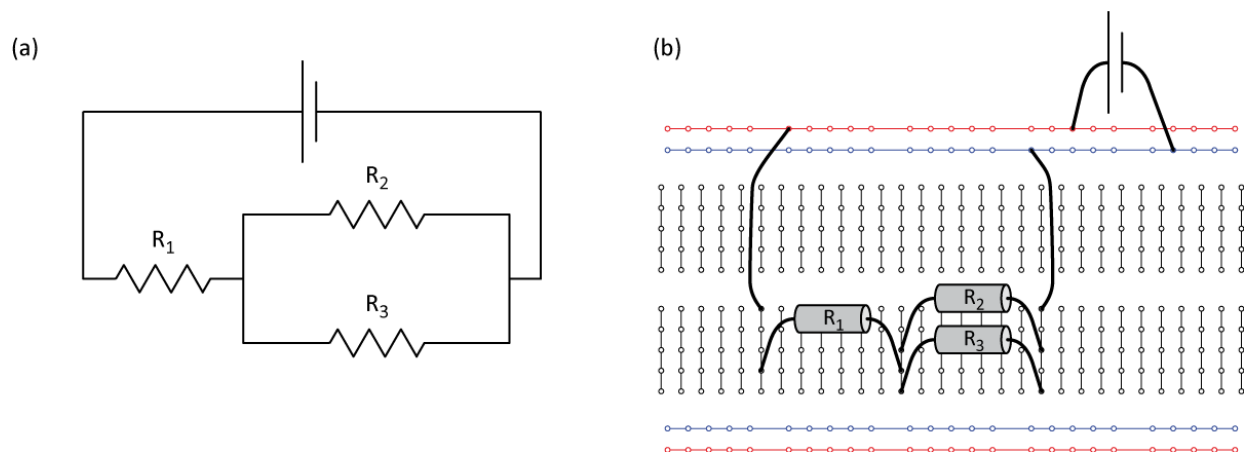

**Figure 4 - (a) Circuit diagram of the resistors from Figure 2 connected to a power supply. (b) How to prepare the circuit presented in (a) using the hidden connections of a breadboard.**