

Simple Measurements & Free fall

1st year physics laboratories

University of Ottawa

<https://uottawa.brightspace.com/d2l/home>

SIMPLE MEASUREMENTS

The TA will go over the following tutorials.

- Error calculations
 - There is a test on error calculations on the lab website.
 - You may complete the test as many times as you want until the deadline. Only your highest mark will be recorded.
- How to use the following instruments:
 - Meter stick
 - Vernier caliper
- Rounding and significant figures.

ERROR CALCULATIONS

Propagation of errors: General formula

If the result R is a function of measurements x, y, \dots where $R = f(x, y, \dots)$ the general formula for the propagation of errors is :

$$\Delta R = \sqrt{\left(\frac{\partial R}{\partial x}\right)^2 \Delta x^2 + \left(\frac{\partial R}{\partial y}\right)^2 \Delta y^2 + \dots} ,$$

ERROR CALCULATIONS

Propagation of errors: addition and subtraction

If the result R is obtained from a series of additions and subtractions:

$$R = \pm Ax \pm By \pm \dots ,$$

where A and B are constants, then the error on the result R is given by

$$\Delta R = \sqrt{A^2 \Delta x^2 + B^2 \Delta y^2 + \dots}$$

ERROR CALCULATIONS

Propagation of errors: multiplication and division

If the result R is obtained from a series of products: $R = x^A y^B \dots$,

where A and B are constants, then the error on the result R is given by

$$\Delta R = R \sqrt{A^2 \frac{\Delta x^2}{x^2} + B^2 \frac{\Delta y^2}{y^2} + \dots}$$

REPEATED MEASUREMENTS

When dealing with multiple measurements, we use the statistical quantities: **mean** (or average), **standard deviation**, and **standard error (SE)** to interpret our data.

- The **mean** (or average) is an estimate of the “true” value of the measurement.
- The **standard deviation** is a measurement of the “spread” in your data. If you took one more measurement, you can be ~70% sure that this value will be one standard deviation away from your mean.
- The **standard error** is an estimate of the uncertainty in the mean value. If you repeated your experiment, you can be ~70% sure that the new mean will be one standard error away from your original mean.

See tutorial – Repeated Measurements

MEASURING INSTRUMENTS

See tutorial - Measuring techniques

Vernier caliper:
for lengths between
1 cm and 10 cm

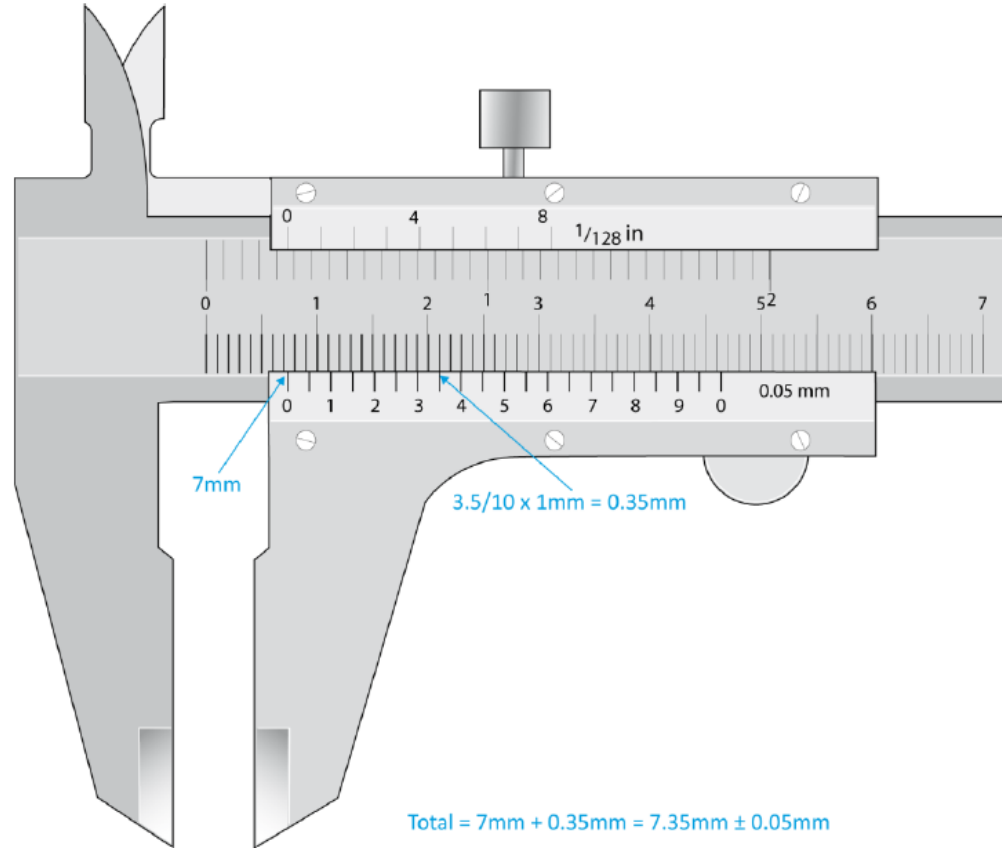

MEASURING INSTRUMENTS

Absolute uncertainties:

- Meter stick: ± 0.5 mm (per reading)
- Vernier caliper: ± 0.05 mm
- Balance: ± 0.1 g
- Stopwatch: $\pm 0.2 - 0.5$ sec

SIGNIFICANT FIGURES AND ROUNDING

➤ The uncertainty on a measurement should only have ONE significant digit.

Example 1: Suppose a relative uncertainty of 0.5% on the gravitational acceleration: $g = 978.325\text{cm/s}^2 \pm 0.5\%$.

Step 1: Multiply the measurement by 0.5%:

$$\Rightarrow (978.325 \pm 4.891625)\text{cm/s}^2.$$

Step 2: Round off the uncertainty to ONE significant digit:

$$\Rightarrow (978.325 \pm 5)\text{cm/s}^2.$$

Step 3: Round off the measured value such that it has the same degree of precision as the uncertainty:

$$\Rightarrow (978 \pm 5)\text{cm/s}^2.$$

A measurement can never have a greater precision than the uncertainty.

LAB 1: OBJECTIVES

- Part 1: Length measurement
 - Measure dimensions of objects to calculate their volume and density
 - Determine material type from a density table
 - Use uncertainty and perform error calculations
- Part 2: Time measurement
 - Measure the period of oscillation of a mass-spring system
 - Determine statistical quantities such as average, standard deviation, and standard error
- Part 3: Picket fence free-fall
 - Use automated data acquisition to determine velocity of a free-falling object.
 - Generate a graph of velocity vs. time for the object and use a linear regression tool to determine the gravitational acceleration constant, g .

Part 1 - Length measurement

The objects and instruments:

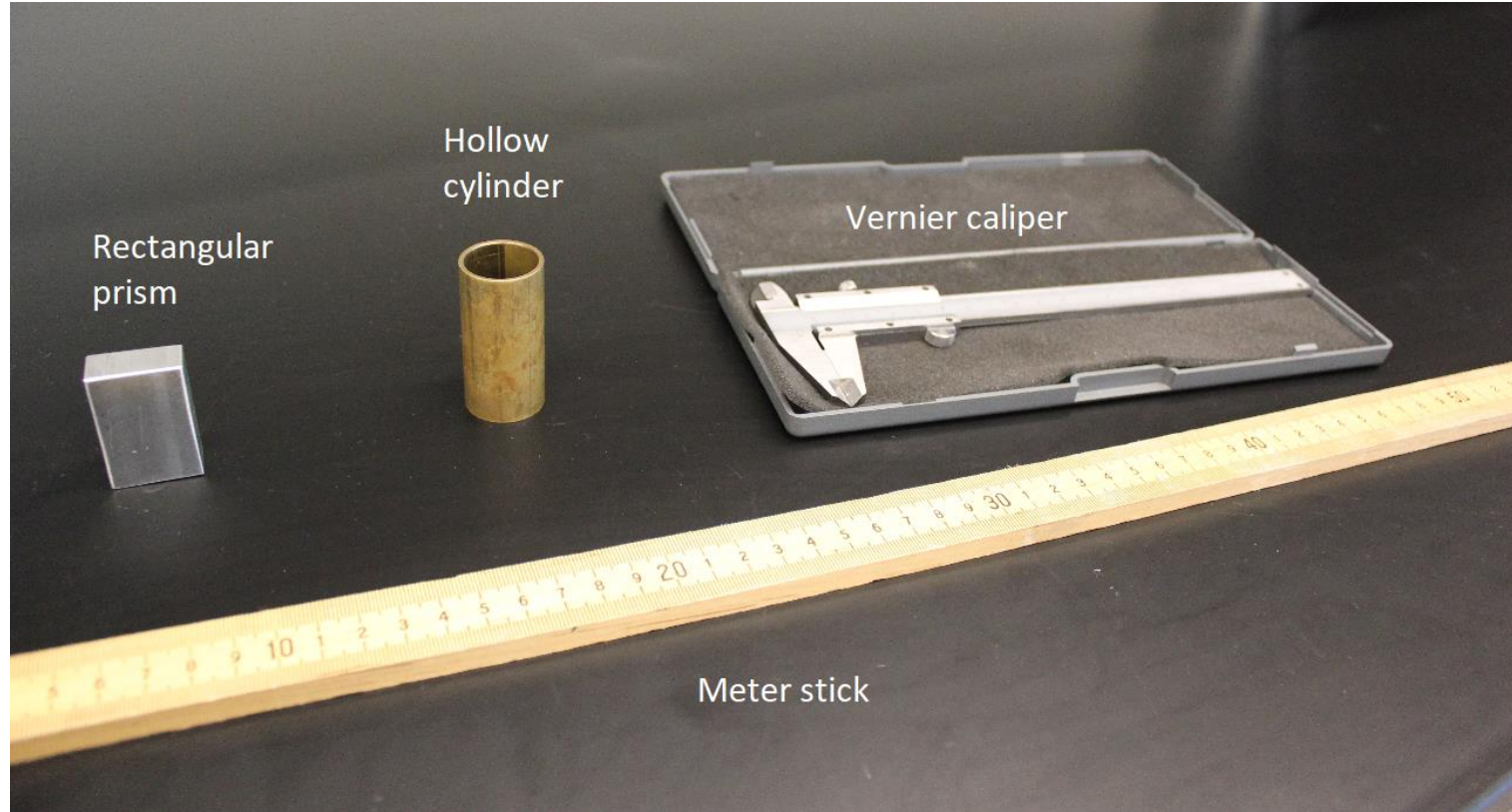

Part 2 - Time measurement

The mass-spring system:

Record the period of oscillation for the 200 g mass on the spring.

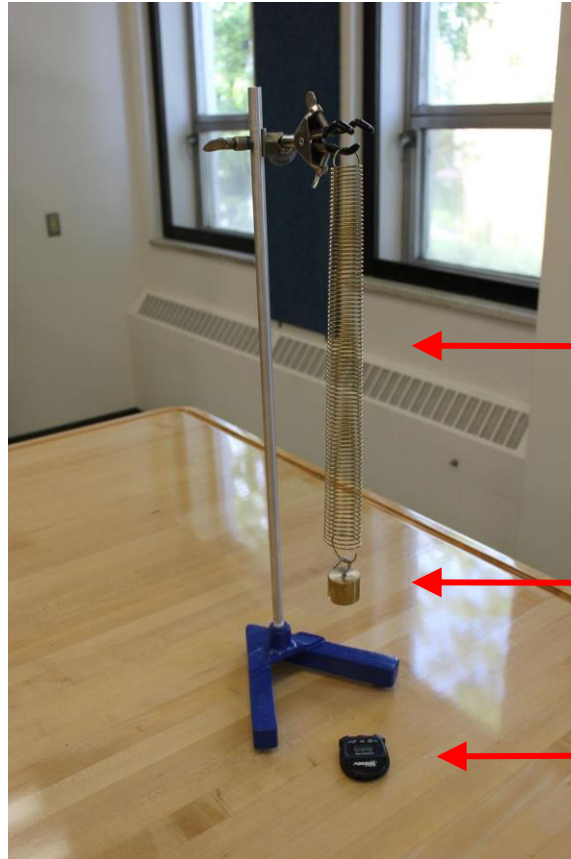

Spring

Mass (200 g)

Stopwatch

Part 3 - Picket fence free fall

The setup:

Record velocity and time data for the picket fence falling through the photogate.

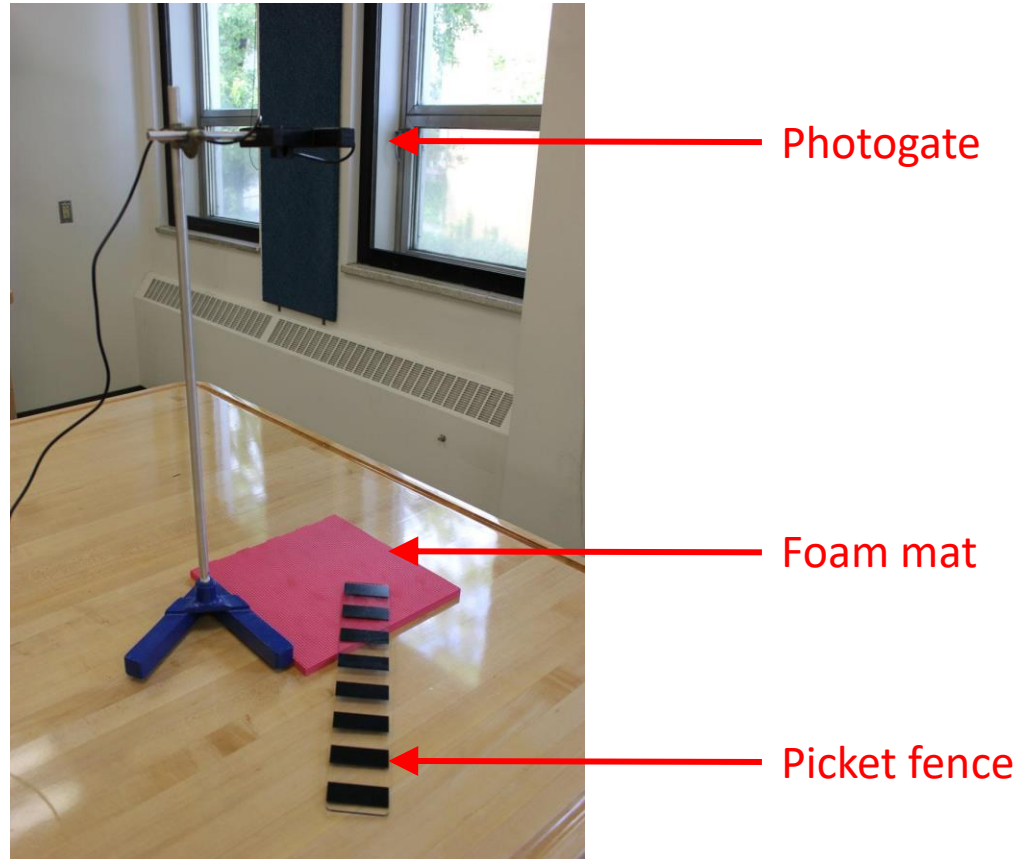

CLEAN UP

- Turn off the computer.
Don't forget to pick up your USB key if you used one!
- Put back the objects and measuring instruments all together neatly on your table.
- Recycle scrap paper and throw away any garbage. Leave your station as clean as you can.
- Push back the monitor, keyboard and mouse. Also please push your chairs back under the table.

DUE DATE

The report is due in one week before 5 pm (for fall/winter). (Spring: 4:00 pm!)

Please drop off your report in the LAB dropoff box located in the central corridor of STEM 3rd floor, south tower.

REMINDER: TESTS!

Do the 4 tests in Exp. 0 folder before the due date!

PRE-LAB

Don't forget to do your pre-lab for Exp. 2!
Don't wait until the last minute, there will be no extension for students experiencing technical problems a few minutes before the deadline!!

NEXT LAB

Your next lab is not a take-home! It will be due at the end of the lab session!